

BASIC M18

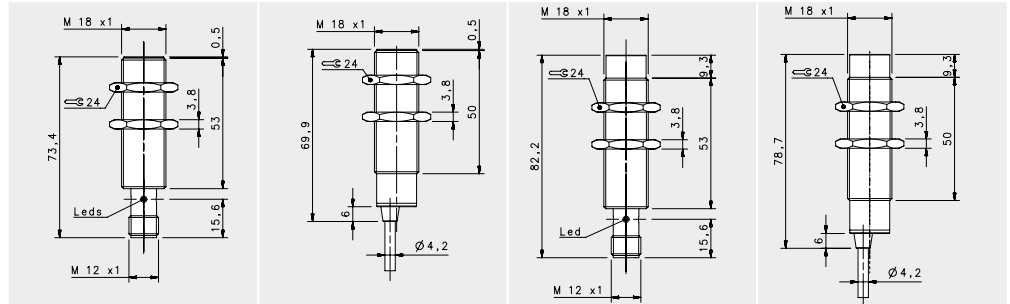

STANDARD

				FLUSH		NON FLUSH	
NOMINAL SWITCHING DISTANCE				M12 conn 5 mm	cable 5 mm	M12 conn 8 mm	cable 8 mm
10-30 Vdc	PNP/NPN NO-NC	4 wires	order No.	IS-18-A0-S2 95B064260	IS-18-A0-03 95B064230	IS-18-C0-S2 95B064280	IS-18-C0-03 95B064240
10-30 Vdc	PNP NO	3 wires	order No.	IS-18-A1-S2 95B061351	IS-18-A1-03 95B061341	IS-18-C1-S2 95B061751	IS-18-C1-03 95B061741
10-30 Vdc	PNP NC	3 wires	order No.	IS-18-A2-S2 95B061371	IS-18-A2-03 95B061361	IS-18-C2-S2 95B061771	IS-18-C2-03 95B061761
10-30 Vdc	NPN NO	3 wires	order No.	IS-18-A3-S2 95B061311	IS-18-A3-03 95B061301	IS-18-C3-S2 95B061711	IS-18-C3-03 95B061701
10-30 Vdc	NPN NC	3 wires	order No.	IS-18-A4-S2 95B061331	IS-18-A4-03 95B061321	IS-18-C4-S2 95B061731	IS-18-C4-03 95B061721
10-30 Vdc	PNP NO-NC	4 wires	order No.	---	---	---	---
10-30 Vdc	NPN NO-NC	4 wires	order No.	---	---	---	---
10-30 Vdc	NO-NC	2 wires	order No.	IS-18-A9-S2 95B063941	IS-18-A9-03 95B064300	IS-18-C9-S2 95B064340	IS-18-C9-03 95B064310
20-250 Vac/Vdc	NO	2 wires	order No.	---	---	---	---
20-250 Vac/Vdc	NC	2 wires	order No.	---	---	---	---
20-250 Vac	NO	2/3wires	order No.	---	---	---	---
10-30 Vdc	Analog 0-20 mA	3 wires	order No.	---	---	---	---
NAMUR amplifier	NAMUR	2 wires	order No.	---	---	---	---

Nominal Voltage	10-30 Vdc (-15/10%)	10-30 Vdc (-15/10%)	10-30 Vdc (-15/10%)	10-30 Vdc (-15/10%)
Residual Ripple	< 10%	< 10%	< 10%	< 10%
Hysteresis	< 10%	< 10%	< 10%	< 10%
Max. Output Current	200 mA	200 mA	200 mA	200 mA
Min. Output Current	> 1,6 mA (2wires ver.)	> 1,6 mA (2wires ver.)	> 1,6 mA (2wires ver.)	> 1,6 mA (2wires ver.)
Residual Current	< 10 mA	< 10 mA	< 10 mA	< 10 mA
Voltage Drop	< 1,8V; < 6,5 V (2wires ver.)	< 1,8V; < 6,5 V (2wires ver.)	< 1,8V; < 6,5 V (2wires ver.)	< 1,8V; < 6,5 V (2wires ver.)
Operation Led	Yellow	Yellow	Yellow	Yellow
Switching Frequency	1000 Hz/200 Hz (2 wires NO-NC)	1000 Hz/200 Hz (2 wires NO-NC)	1000 Hz/200 Hz (2 wires NO-NC)	1000 Hz/200 Hz (2 wires NO-NC)
Start Up Delay	< 50 ms	< 50 ms	< 50 ms	< 50 ms
Repeatability	< 3%	< 3%	< 3%	< 3%
Short Circuit Protection	Present (self-resetting)	Present (self-resetting)	Present (self-resetting)	Present (self-resetting)
Electric Protection	Against polarity reversal inductive loads	Against polarity reversal inductive loads	Against polarity reversal inductive loads	Against polarity reversal inductive loads
Temperature Limit	(-25 ... +60 °C)	(-25 ... +60 °C)	(-25 ... +60 °C)	(-25 ... +60 °C)
Protection Degree	IP67	IP67	IP67	IP67
Cable Length	---	2 m	---	2 m
Cable Section	---	2 x 0,34 mm ² 3 x 0,14 mm ² 4 x 0,25 mm ²	---	2 x 0,34 mm ² 3 x 0,14 mm ² 4 x 0,25 mm ²
Housing Material	Nickel-plated brass	Nickel-plated brass	Nickel-plated brass	Nickel-plated brass
Active face	LCP	LCP	LCP	LCP
Tightening torque	30Nm	30Nm	30Nm	30Nm
Weight - Cable Output	---	145g	---	145g
Weight - Connector Output	95g	---	95g	---

BASIC M18

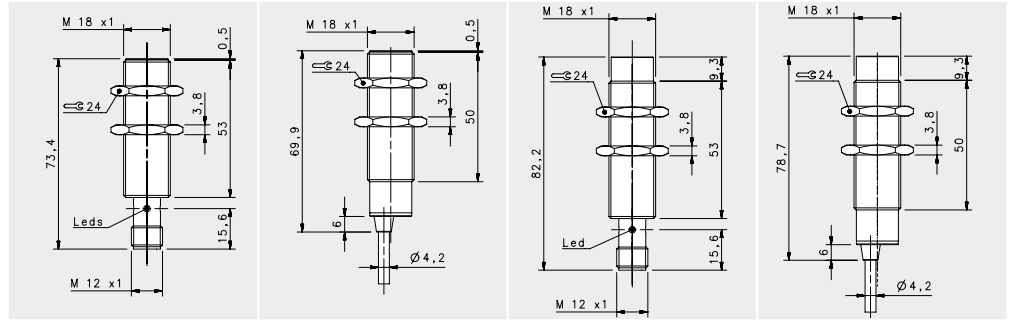

STANDARD X2

				FLUSH		NON FLUSH	
				M12 conn	cable	M12 conn	cable
				8 mm		14 mm	
NOMINAL SWITCHING DISTANCE			order No.				
10-30 Vdc	PNP/NPN NO-NC	4 wires		IS-18-E0-S2 95B067310	IS-18-E0-03 95B067270	IS-18-F0-S2 95B067330	IS-18-F0-03 95B067290
10-30 Vdc	PNP NO	3 wires		IS-18-E1-S2 95B067050	IS-18-E1-03 95B067810	IS-18-F1-S2 95B067040	IS-18-F1-03 95B067880
10-30 Vdc	PNP NC	3 wires		IS-18-E2-S2 95B067780	IS-18-E2-03 95B067820	IS-18-F2-S2 95B067850	IS-18-F2-03 95B067890
10-30 Vdc	NPN NO	3 wires		IS-18-E3-S2 95B067790	IS-18-E3-03 95B067830	IS-18-F3-S2 95B067860	IS-18-F3-03 95B067900
10-30 Vdc	NPN NC	3 wires		IS-18-E4-S2 95B067800	IS-18-E4-03 95B067840	IS-18-F4-S2 95B067870	IS-18-F4-03 95B067910
10-30 Vdc	PNP NO-NC	4 wires		---	---	---	---
10-30 Vdc	NPN NO-NC	4 wires		---	---	---	---
10-30 Vdc	NO-NC	2 wires		IS-18-E9-S2 95B067320	IS-18-E9-03 95B067280	IS-18-F9-S2 95B067340	IS-18-F9-03 95B067300
20-250 Vac/Vdc	NO	2 wires		---	---	---	---
20-250 Vac/Vdc	NC	2 wires		---	---	---	---
20-250 Vac	NO	2/3wires		---	---	---	---
10-30 Vdc	Analog 0-20 mA	3 wires		---	---	---	---
NAMUR amplifier	NAMUR	2 wires		---	---	---	---
Nominal Voltage				10-30 Vdc (-15/10%)	10-30 Vdc (-15/10%)	10-30 Vdc (-15/10%)	10-30 Vdc (-15/10%)
Residual Ripple				< 10%	< 10%	< 10%	< 10%
Hysteresis				< 10%	< 10%	< 10%	< 10%
Max. Output Current				200 mA	200 mA	200 mA	200 mA
Min. Output Current				---	---	---	---
Residual Current				< 10 mA	< 10 mA	< 10 mA	< 10 mA
Voltage Drop				< 1,2 V (I=100mA)	< 1,2 V (I=100mA)	< 1,2 V (I=100mA)	< 1,2 V (I=100mA)
Operation Led				Yellow	Yellow	Yellow	Yellow
Switching Frequency				400 Hz	400 Hz	100 Hz	100 Hz
Start Up Delay				< 50 ms	< 50 ms	< 50 ms	< 50 ms
Repeatability				< 3%	< 3%	< 3%	< 3%
Short Circuit Protection				Present (self-resetting)	Present (self-resetting)	Present (self-resetting)	Present (self-resetting)
Electric Protection				Against polarity reversal inductive loads	Against polarity reversal inductive loads	Against polarity reversal inductive loads	Against polarity reversal inductive loads
Temperature Limit				(-25 ... +70 °C)	(-25 ... +70 °C)	(-25 ... +70 °C)	(-25 ... +70 °C)
Protection Degree				IP67	IP67	IP67	IP67
Cable Length				---	---	---	---
Cable Section				---	2 x 0,34 mm ² 3 x 0,14 mm ² 4 x 0,25 mm ²	---	2 x 0,34 mm ² 3 x 0,14 mm ² 4 x 0,25 mm ²
Housing Material				Nickel-plated brass	Nickel-plated brass	Nickel-plated brass	Nickel-plated brass
Active face				LCP	LCP	LCP	LCP
Tightening torque				30Nm	30Nm	30Nm	30Nm
Weight - Cable Output				---	---	145g	---
Weight - Connector Output				95g	95g	---	---

